

Backup Brake Valve (BBV)



Description : Backup Brake Valve (BBV) is used for application / release of Auto Brake during electronic failure. It is operated by means of a 'Joystick' type handle, which controls the charging and discharging of the brake pipe.

Application : 3 Phase Electric Locomotives

Customer : Indian Railways

Key benefits of product :

- Pure pneumatic BP control
- Time dependent pressure control
- Can be used for full brake application or partial brake application
- Limiting valve to restrict the maximum BP pressure

Specifications :

- Handle Positions : Release, Neutral , Apply
- Weight : 4.5 Kg
- Working Pressure : 10 Kg/cm²

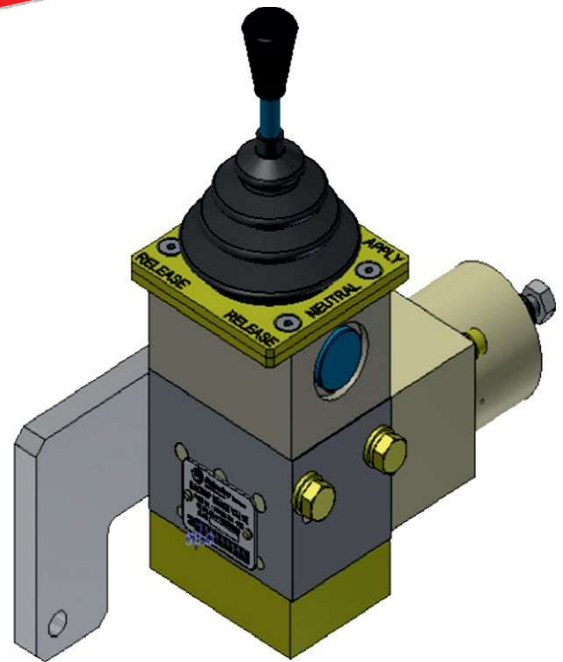

Backup Brake Valve

